

UChile RoadRunners – UCH H2 Robot

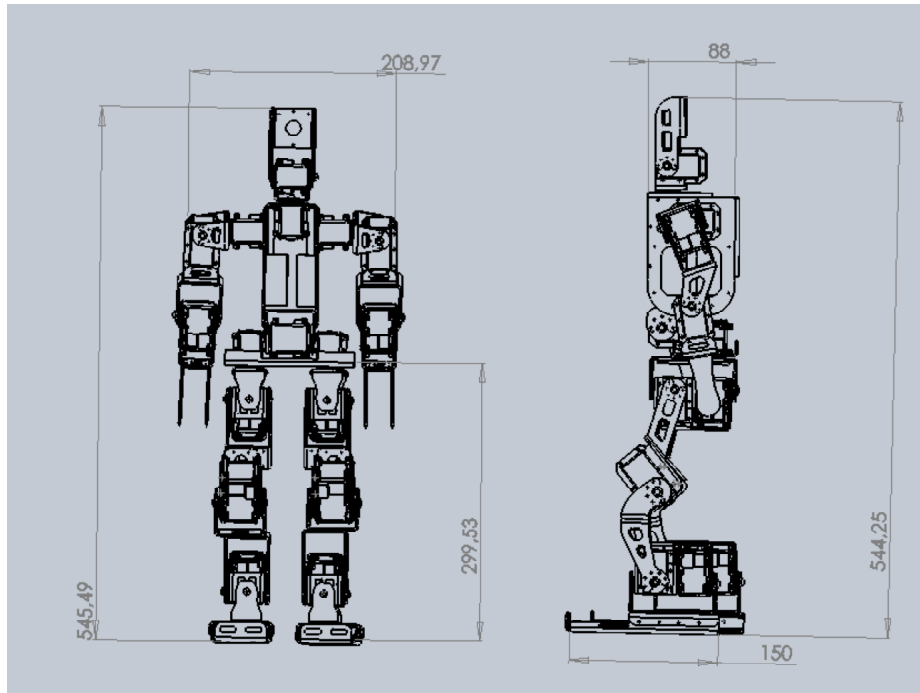

UChile RoadRunners – Hajime HR18 Robots

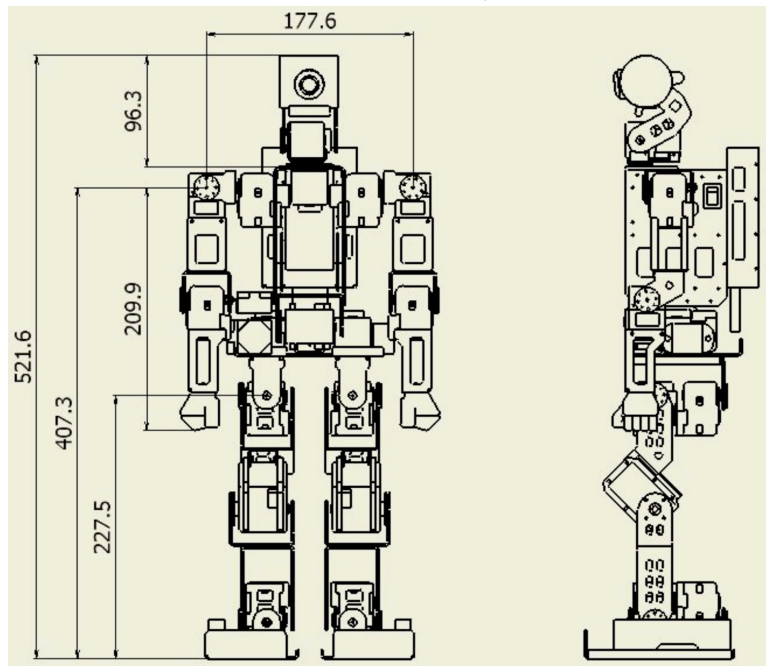

Hardware specifications

Player	Field Players (2)	Goalie Player (1)
Robot	Hajime HR18	UCH H2
Height	540 mm	560 mm
Weight	3.7 kg	3.8kg
Servo Motors Dynamixel Robot Actuator	18x DX-117 3x RX 64	18x RX-28 3x RX 64
Degrees of freedom	21 leg: 6x2 arm: 3x2 waist: 1 neck: 2	21 leg: 6x2 arm: 3x2 waist: 1 neck: 2
Batteries	2x Li-Po 7.4V, 4000mAh	2x Li-Po 7.4V, 4000mAh
Internal Sensors		
Joint Angle Encoder	21	21
Accelerometer	ADXL320	ADXL320
Gyroscope	IDG-300	IDG-300
Walking Speed	20 - 30 cm per second	10 - 25 cm per second
Camera	Philip SPC900NC	Philip SPC900NC
Sensor	CCD	CCD
Interpolated snapshot resolution	1.3 Mpixels	1.3 Mpixels
Max. frame rate	90 fps	90 fps
Lens	F2.2, D55°	F2.2, D55°
White balance	2600 - 7600 k	2600 - 7600 k
Min. illuminance	< 1 lux	< 1 lux
Colour depth	24 bit	24 bit
PC Link:	USB 1.1	USB 1.1
Control	Autonomous at frequency 10 ms	Autonomous at frequency 10 ms
Internal Controller	32bit DSP TMS320F28335 150MHz	32bit DSP TMS320F28335 150MHz
PC	Axiomtek PICO820VGA-Z530	Axiomtek PICO820VGA-Z530
Processor	Intel® Atom processor Z530 1.6GHz	Intel® Atom processor Z530 1.6GHz
Memory	System memory (RAM) 2 GB 667MHz Compact Flash memory 4GB 133x	System memory (RAM) 2 GB 667MHz Compact Flash memory 4GB 133x
Wireless LAN	USB wireless adaptor, 802.11 b/g, Linux (Debian)	USB wireless adaptor, 802.11 b/g, Linux (Debian)
Operating system	Linux (Debian)	Linux (Debian)
Interfaces	USB 2.0 camera and wireless adaptor I/O buttons	USB 2.0 camera and wireless adaptor I/O buttons